

OEM Air Pressure Sensing Switch with Fixed Set Point

Application

Series RSS-495 switches feature customer-specified fixed set points between 0.20" w.c. and 1.0" w.c. They are specifically designed for OEM markets. They are used to sense positive or negative air pressure, and are equipped with various sample line connections, terminal styles, and mounting arrangements.

General Description & Operation

The thermoplastic housing contains a diaphragm and snap-acting switch. Barbed sample line connectors on each side of the diaphragm accept flexible tubing. The electrical connection consists of male quick connect terminals.

The snap action switch can be actuated by a positive or negative pressure, or by a pressure differential.

Mounting (Figure 1)

Select a mounting location free from vibration. Mount with the diaphragm in any vertical plane in order to maintain the specified operating set point. Avoid mounting with the sample line connections directed upward. Surface mount via the two 0.14" slots in the bracket.

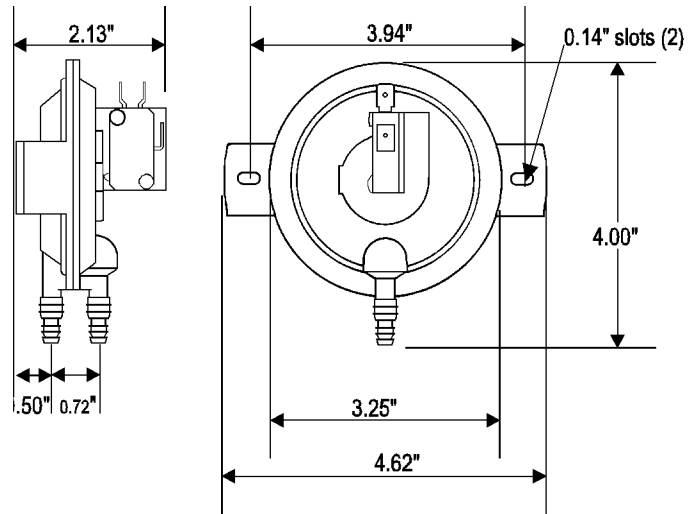

Dimensions in Inches
(Millimeters)

Air Sampling Connection (see Figure 2, page 2)

The RSS switches are equipped with two concentric barbed slip-on sample line connections which will accept a wide range of flexible tube sizes ($\frac{1}{4}$ " and $\frac{3}{8}$ " ID diameter). Refer to Figure 2 to identify the **High inlet (H)** and the **Low inlet (L)**. Connect the sample lines as follows:

Positive Pressure Only: Connect the sample line to H; L remains open to the atmosphere.

Negative Pressure Only: Connect the sample line to L; H remains open to the atmosphere.

Two Negative Samples: Connect higher negative sample to L; lower sample to H.

Two Positive Samples: Connect higher positive sample to H; lower sample to L.

One Positive and One Negative: Connect positive sample to H; connect negative sample to L.

Electrical Connections

The snap switch has male quick connect terminals. Before pressure is applied to the diaphragm, the switch contacts will be in the deactivated position as shown in Figure 3.

Distributed by:

Figure 1

Mount with the diaphragm in any vertical plane. (Note: sampling connections should not point up.)

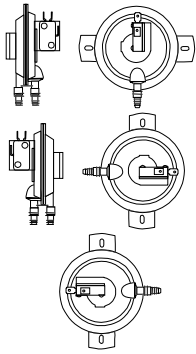

Fig. 2

Air Sampling Connections

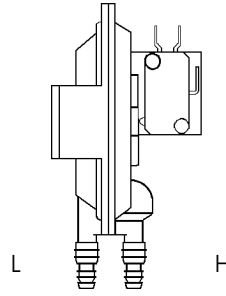
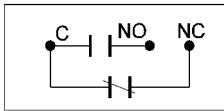

Fig. 3

SPDT Switch, Type RSS: without pressure applied to the diaphragm, switch contacts are in the position shown.



Pressure Conversion Table

1" H ₂ O =	.0361 lbs./sq. in. or .0735 in. mercury
1" Hg. =	0.491 lbs./sq. in. or 13.6 in. water
1 psi =	27.7 in. water or 2.036 in. mercury

Location of Sample Lines for Typical RSS Applications.

<p>Fan operation or true air flow with little or no static pressure.</p>	<p>Fan operation or air flow with no static pressure.</p>
<p>Fan operation and true air flow with varying amounts of static pressure.</p>	<p>Suction or fan operation.</p>
<p>Prove positive static pressure.</p>	<p>Negative pressure increases as filter gets dirty.</p>

SPECIFICATIONS

Cleveland Controls

**Series RSS-495
Air Pressure Sensing
Switches**

Set Point:

Factory calibrated to meet customer design specifications, from 0.20 ± 0.05" w.c. to 1.0" w.c.

Maximum Pressure:

1 psi (0.06 bar)

Electrical Rating:

5 amp noninductive 120 to 277 V AC
1 amp pilot duty (120 va) at 120 V AC

Electrical Switch:

Snap-action switch

Contact Arrangement:

SPDT, SPST/NO or SPST
NC logic

Electrical Connections:

Complying with the latest requirements of NEMA standards

Operating Temperature

Range: -40.0 to 190.0 F
(-40.0 to 88.0 C)

Mounting Position:

Diaphragm in any vertical plane to obtain specified operating set point.

Sample Line Connectors:

Barbed fittings will accept 1/4" ID or 3/8" ID flexible, slip-on tubing.

Shipping Weight: 1/4 lb.

Approvals: UL, CSA, CE, NRTL, & AUST. GAS ASSOC.

Options:

- Bleed hole
- OEM mounting bracket
- Flow restriction orifice
- Sample line connectors for metallic tubing
- 90° elbow connector adapters
- Sample line adapter for 1/8" ID tubing

Consult factory for other options!